

# WALL BRACKET FOR ULTRASONIC SENSOR

MLSUPUS

Extension MLSUPUS-EXT

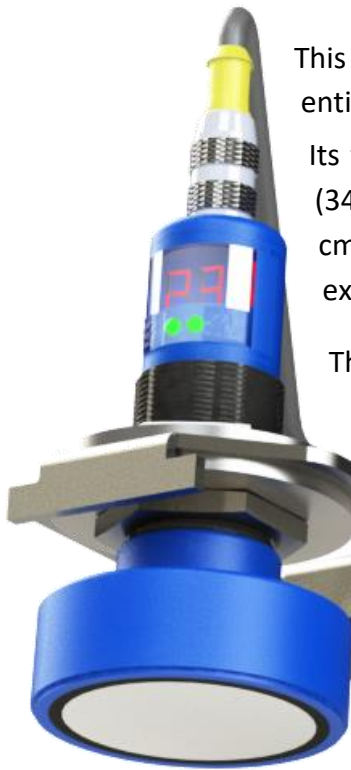

This support is for probes having a body of 1 inch (2.7 cm) in diameter. It is entirely made of high precision laser cut 3mm thick 316 stainless steel.

Its telescopic system allows installations from 4 inches (10.5 cm) to 13 inches (34 cm) from the wall with the base support (MLSUPUS), up to 24 inches (60 cm) with one extension (MLSUPUS-EXT) and 34 inches (87 cm) with a second extension.

The adjustable horizontal support moves the probe 180 degrees to facilitate access during maintenance work. The wall plate allows a vertical adjustment of 20 degrees in both directions.

MLSUPUS includes the following parts: wall plate and base, 2 probe support washers, 3 cement screws, locking pin, bolt and nut assembly.

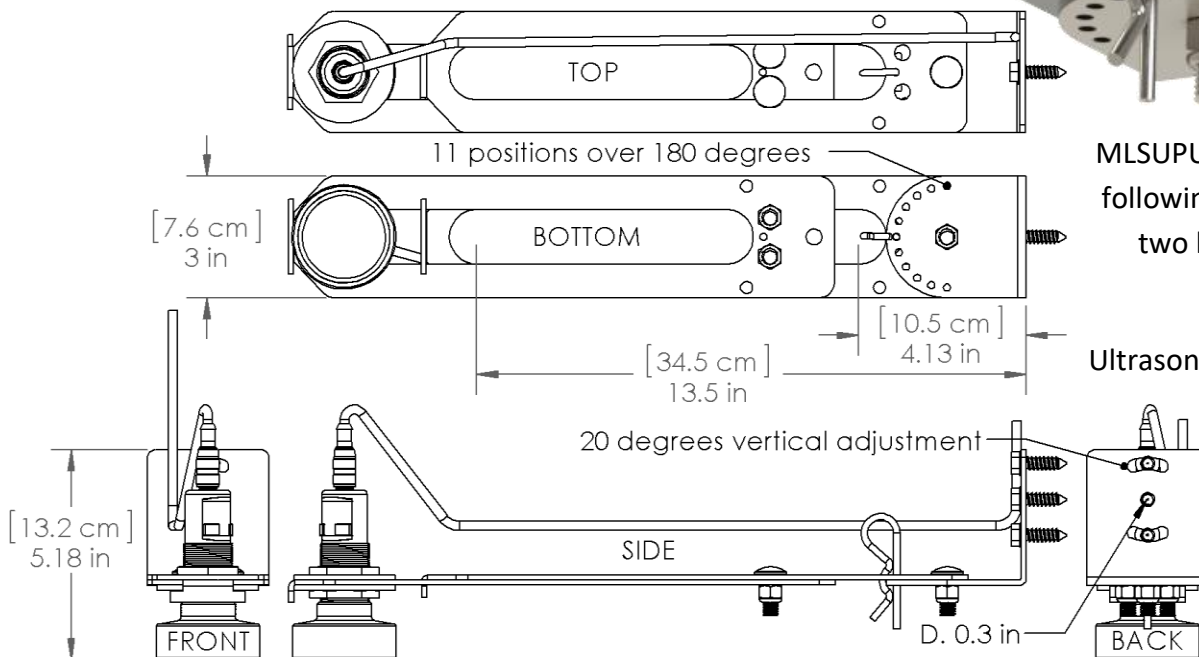

MLSUPUS-EXT includes the following parts: Extension, two bolts, two nuts and two washers.

Ultrasonic sensor and cable not included.

Patent:  
USD 853219S1